

DESCRIPTION AND MATERIAL	<ul style="list-style-type: none">• Wet Pluggable.• Metal to metal key for positive alignment.• 316 Stainless Steel passivated per QQ-P-35 Type VI with naval bronze engaging nut.• Special alloys are available upon request (contact factory).• 10,000 PSI in mated condition.• Bulkhead connector design open face pressure rated to 5000 PSI.• Contacts gold plated per MIL-G-45204.• Engaging nuts have Acme threads for rugged applications and for quick connection.• Working voltage for MKS-200/300/3L00/400-BCR/FCR/CCP is 300 VDC.• Working voltage for MKS-500/700/900-BCR/FCR/CCP is 600 VDC.
CABLE	<ul style="list-style-type: none">• CCP is not terminated to cable unless specified at the time of order• MKS-200/300/3L00/400-BCR/FCR has Type E leads per MIL 16878/4.• MKS-500/700/900-BCR/FCR has Type EE leads per MIL 16878/5.
USES	<ul style="list-style-type: none">• Light and Heavy Duty applications.• Hazardous environment.• Power Transmission.• Signal Telemetry.• ROV applications.
GUIDELINES	<ul style="list-style-type: none">• All mounting and sealing surfaces require a 32 finish.• Lubricate mating surfaces with 3M Silicone Lubricant or equivalent, DO NOT grease! Connectors must be lubricated on a regular basis.• Lubricate o-rings with Dow Corning #111 Valve Lubricant or equivalent.• Use Dust Caps and keep connectors clean to prevent damage in storage and service.• Keep o-ring grooves clean and avoid cuts, nicks and tears on rubber surfaces.• Elastomers can be seriously degraded if exposed to direct sunlight or high ozone levels for extended periods of time.• Clean plugs and receptacles with soap and fresh water. Rinse out with alcohol, allowing connector to air dry.• Replace o-rings when re-using connectors.

MKS(W)-2

METAL KEY RUBBER MOLDED
TITAN™ SERIES

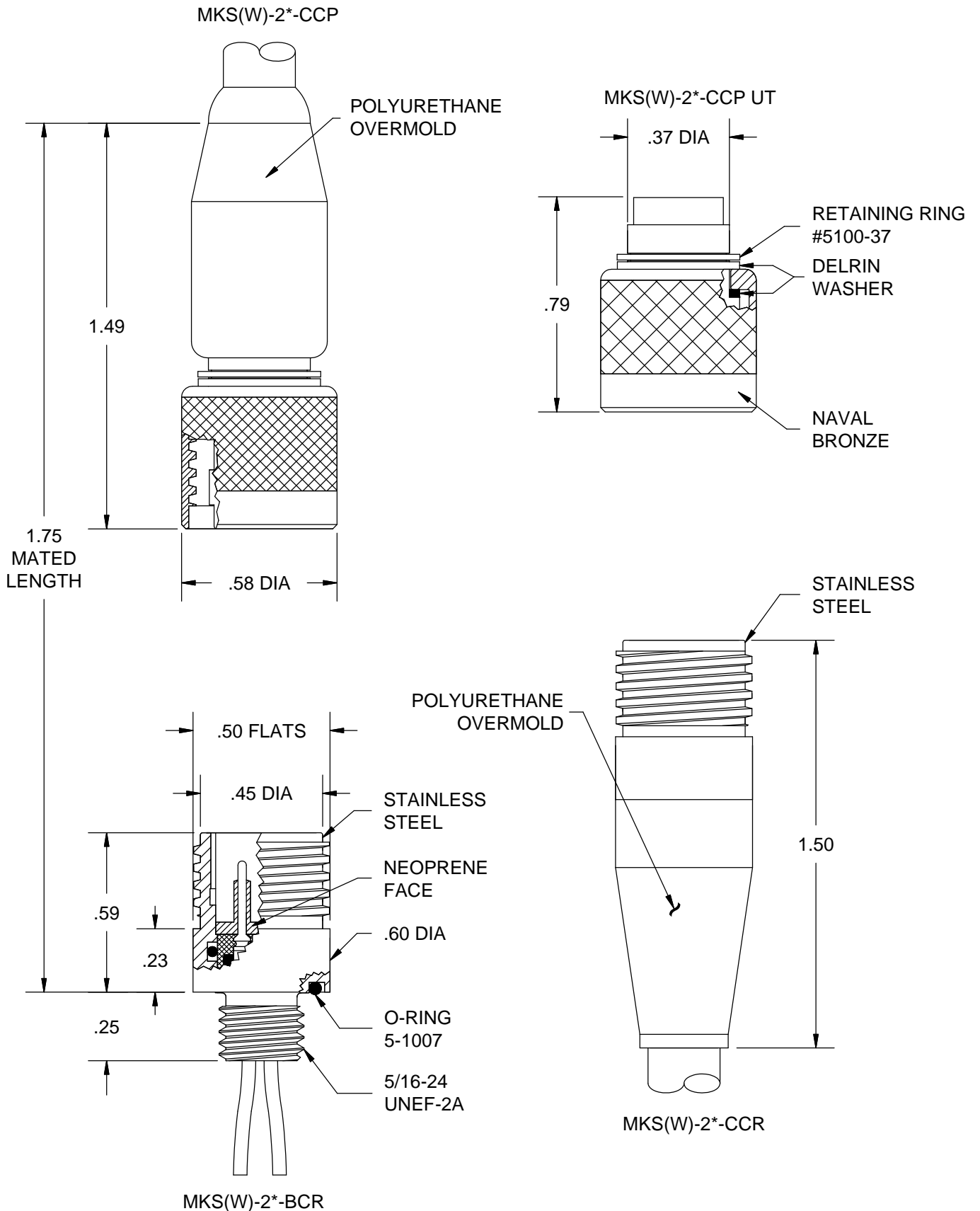
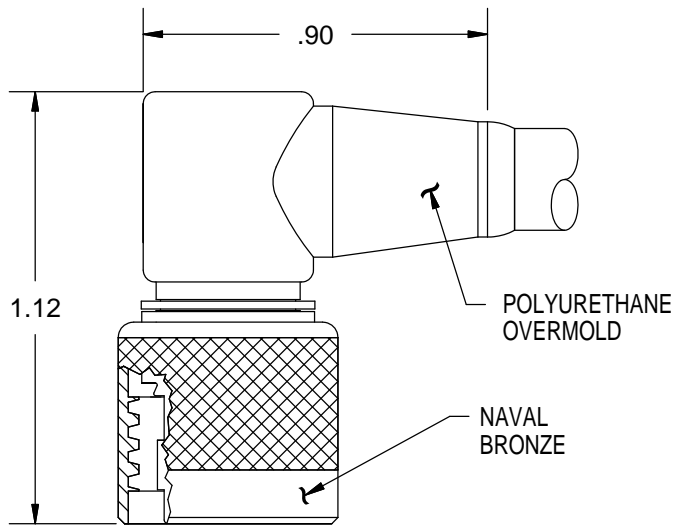
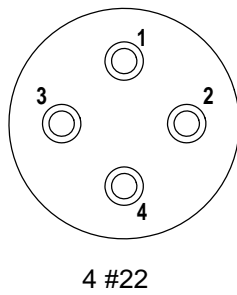

CONTACT CONFIGURATION
(BCR FACE VIEW)



MKS(W)-2*-CCP R/A

MOUNTING TORQUE FOR BCR	not to exceed 50 in-lbs	MATED PRESSURE RATING (psi)	10,000
See page 95 80 for SCP/SCR information			
<p>NOTE: CCP is not terminated to cable unless specified.</p> <p>* Please specify number of contacts.</p> <p>** O-Ring installation tool available - Contact factory for further details.</p>			

MKS(W)-3

METAL KEY WET PLUGGABLE RUBBER MOLDED TITAN™ SERIES

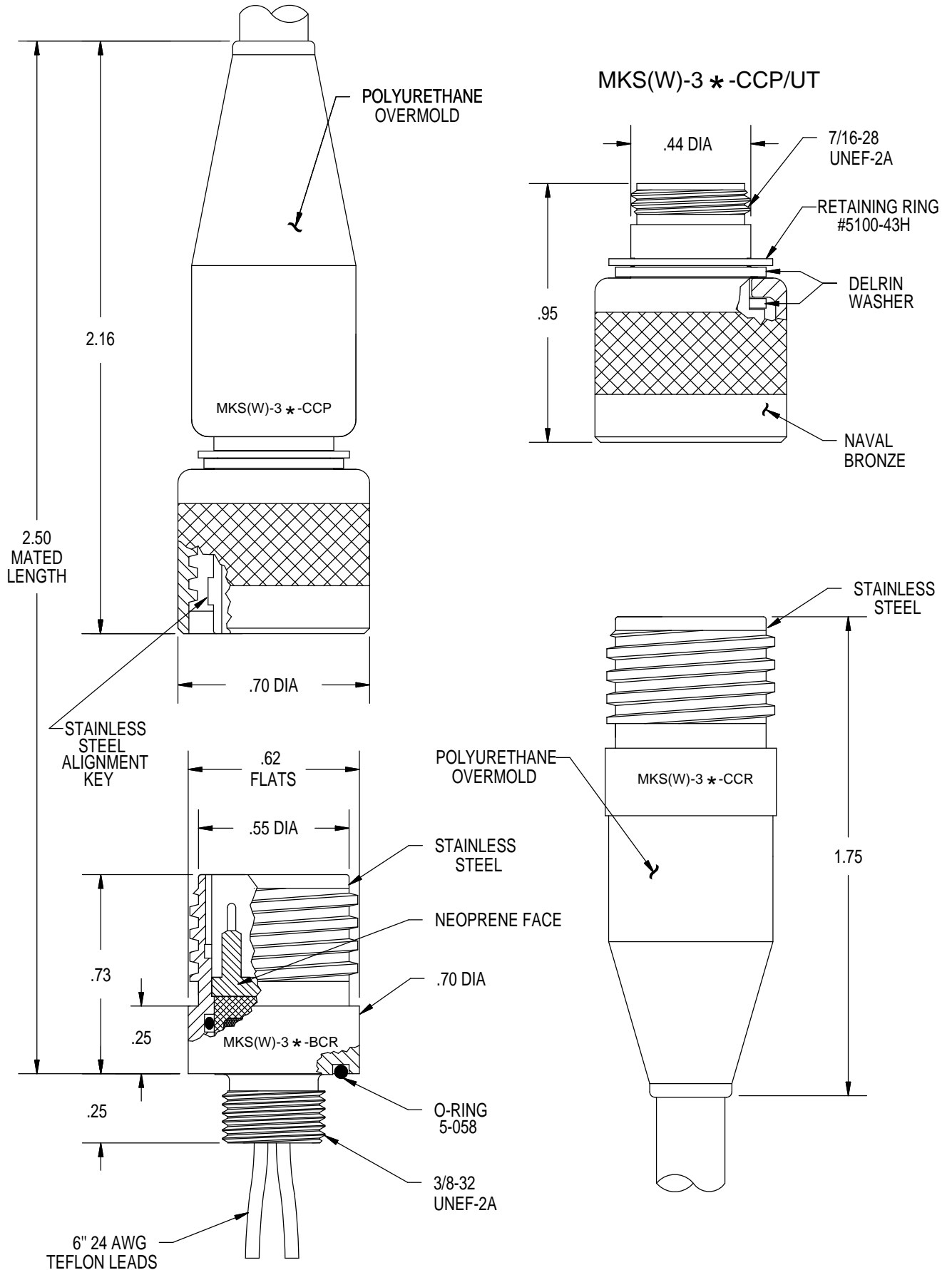

MKS(W)-3

METAL KEY WET PLUGGABLE RUBBER MOLDED TITAN™ SERIES

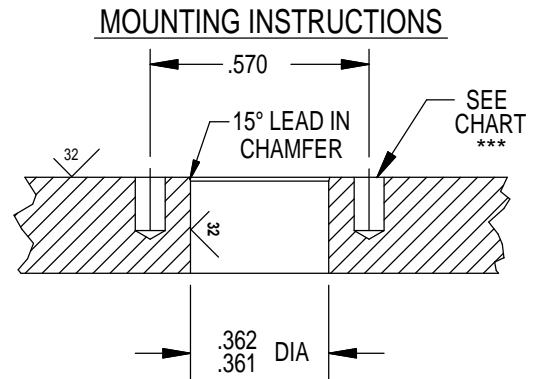
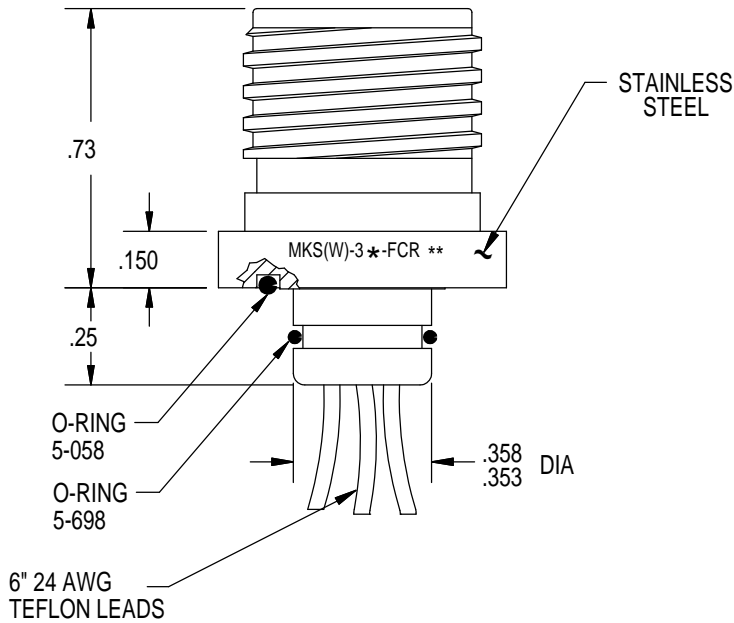
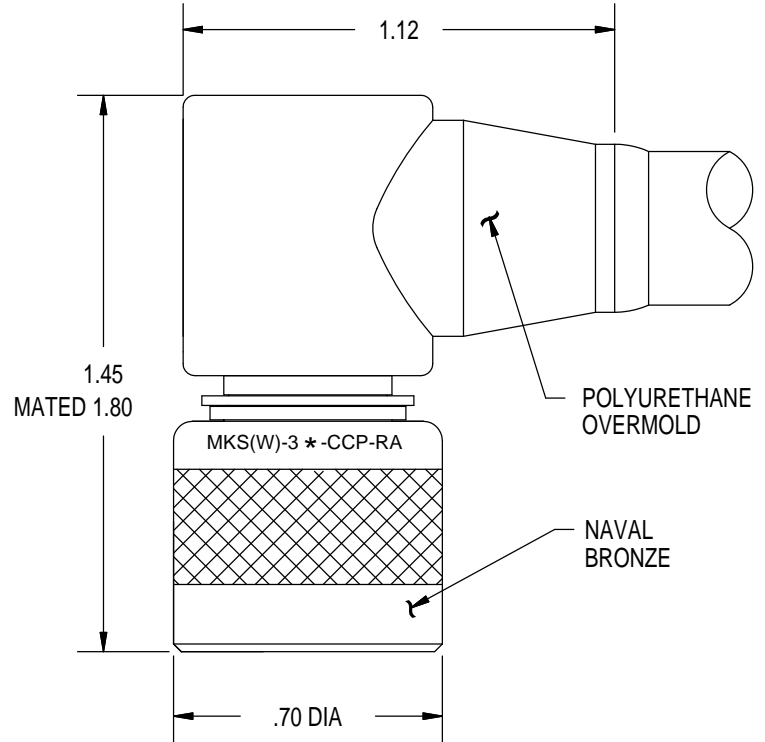
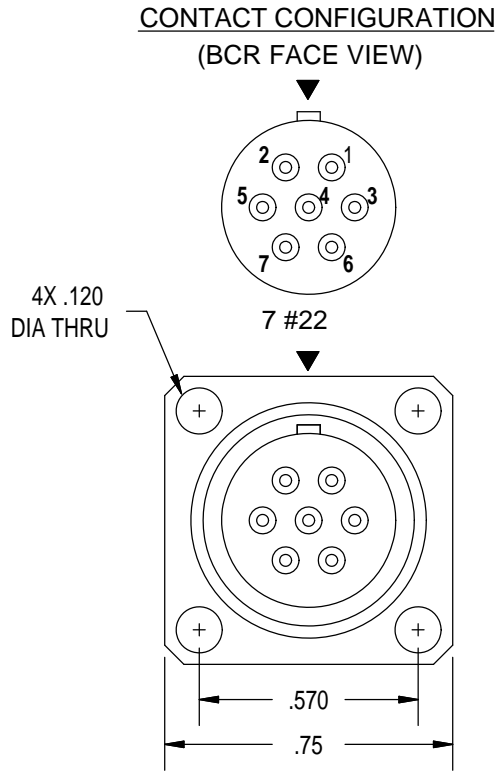

MOUNTING TORQUE FOR BCR	not to exceed 50 in lbs	MATED PRESSURE RATING (psi)	10,000
-------------------------	-------------------------	-----------------------------	--------

See pg. 9580 for SCP/SCR information.

NOTE: CCP is not terminated to cable unless specified.

* Please specify number of contacts.

** Internal assembly same as MKS(W)-3* -BCR (facing page).

*** Blind tapped hole not to penetrate bulkhead, minimum full thread depth 2 times bolt diameter.

MKS(W)-3L10

METAL KEY WET PLUGGABLE RUBBER MOLDED
TITAN™ SERIES

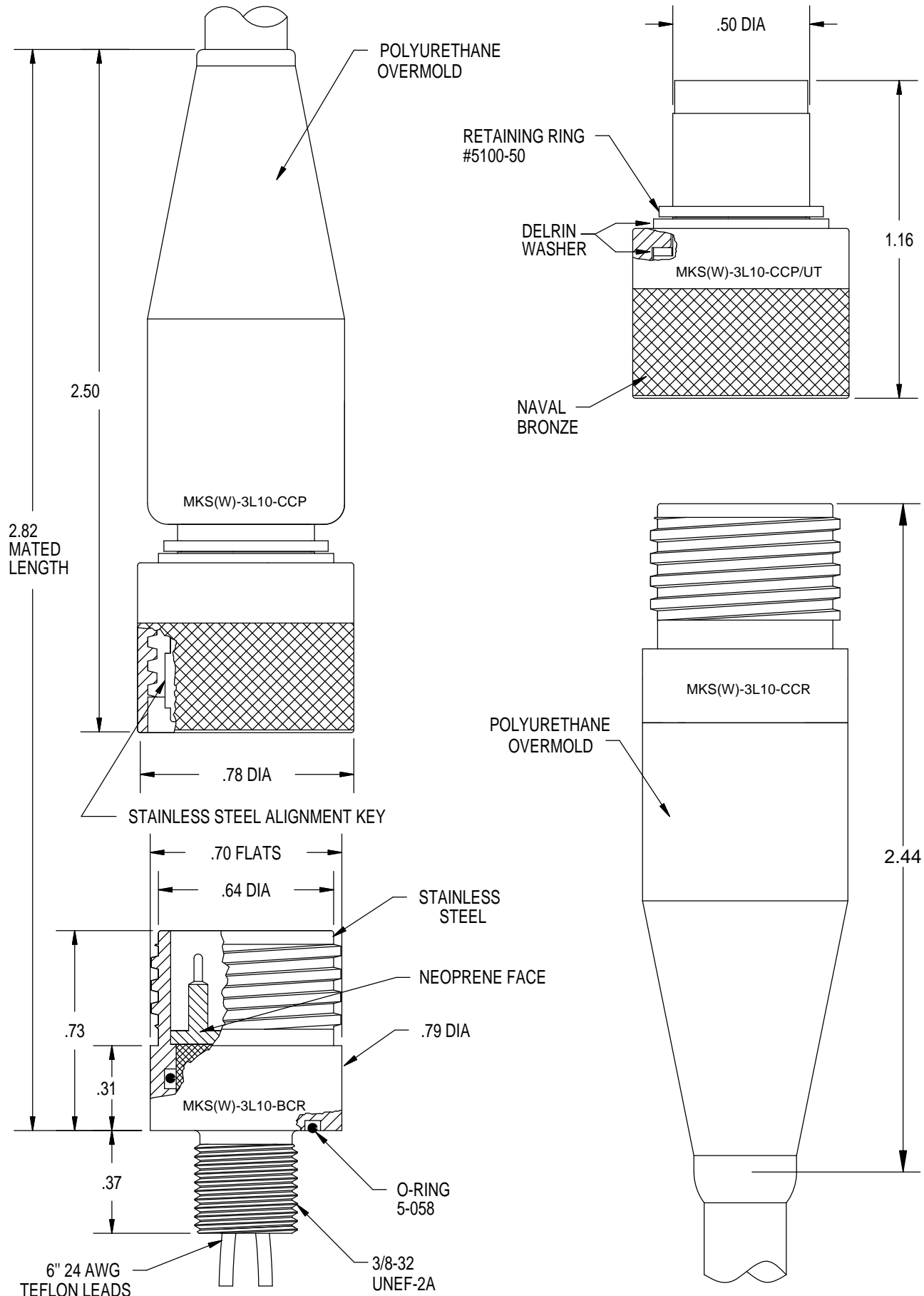

MKS(W)-3L10

METAL KEY WET PLUGGABLE RUBBER MOLDED
TITAN SERIES

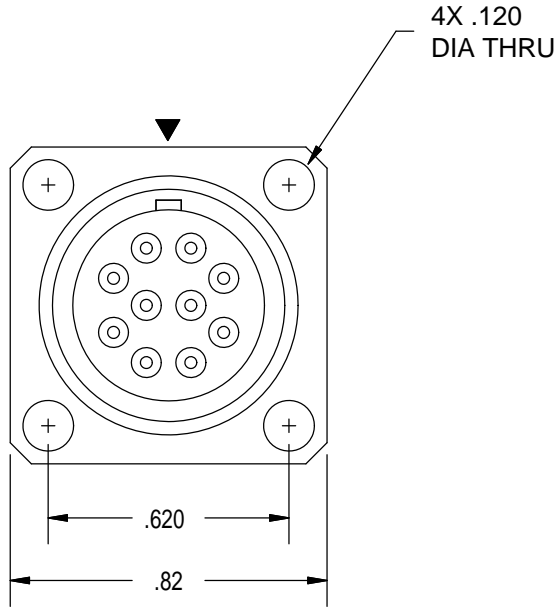

CONTACT CONFIGURATION (BCR FACE VIEW)

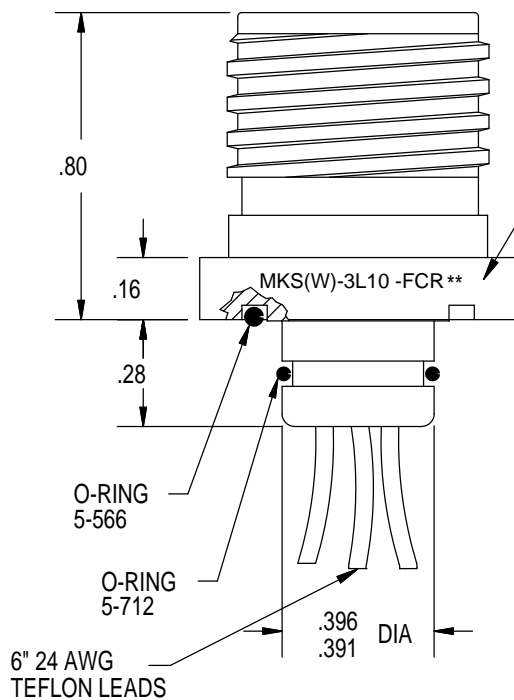
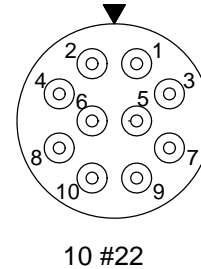

STAINLESS
STEEL

MOUNTING INSTRUCTIONS

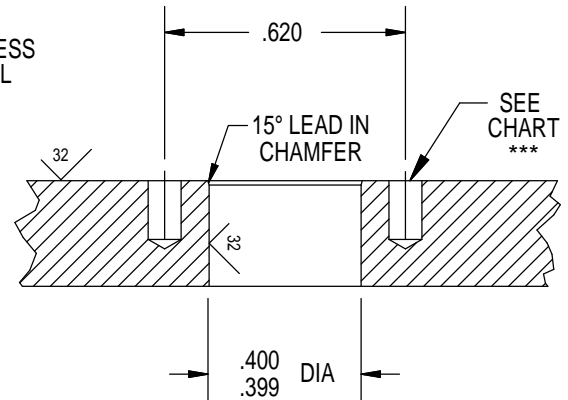

MOUNTING TORQUE FOR BCR	not to exceed 50 in lbs	MATED PRESSURE RATING (psi)	10,000
<p>NOTE: CCP is not terminated to cable unless specified.</p> <p>* Please specify number of contacts.</p> <p>**Internal assembly same as MKS(W)-3L10-BCR (facing page).</p> <p>*** Blind tapped hole not to penetrate bulkhead, minimum full thread depth 2 times bolt diameter.</p>			

MKS(W)-3XL

METAL KEY WET PLUGGABLE RUBBER MOLDED
TITAN™ SERIES

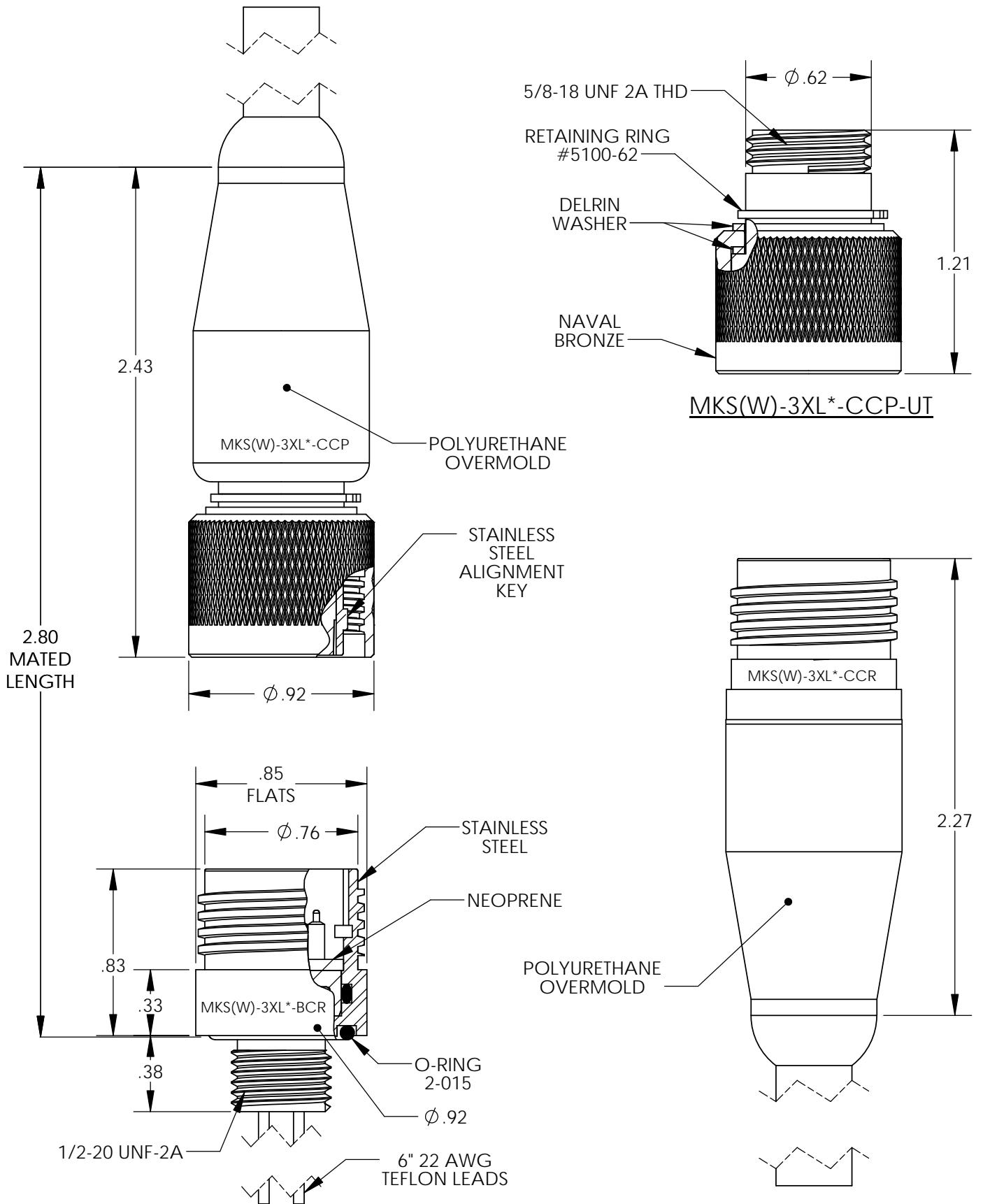

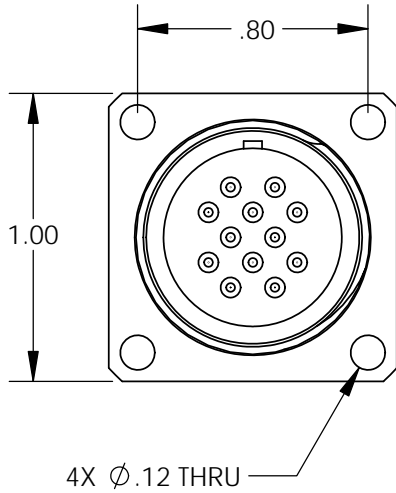

CONTACT CONFIGURATION
(BCR FACE VIEW)

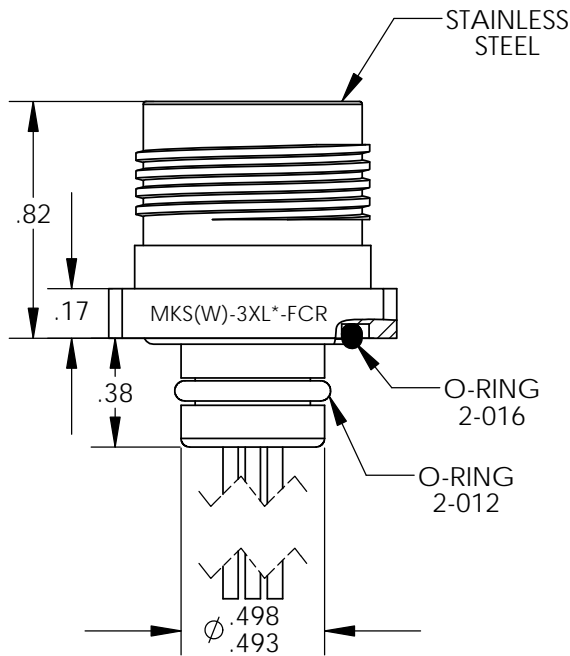
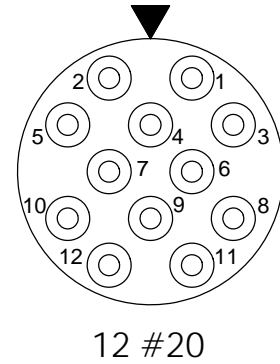

MOUNTING INSTRUCTIONS

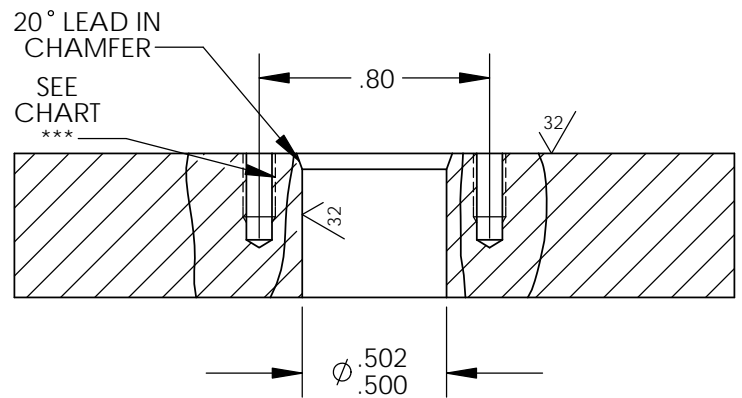

MOUNTING TORQUE FOR BCR	not to exceed 50 in lbs	MATED PRESSURE RATING (psi)	10,000
<p>NOTE: CCP is not terminated to cable unless specified. * Please specify number of contacts. **Internal assembly same as MKS(W)-3XL*-BCR (facing page). *** Blind tapped hole not to penetrate bulkhead, minimum full thread depth 2 times bolt diameter.</p>			

MKS(W)-4

METAL KEY WET PLUGGABLE RUBBER MOLDED TITAN™ SERIES

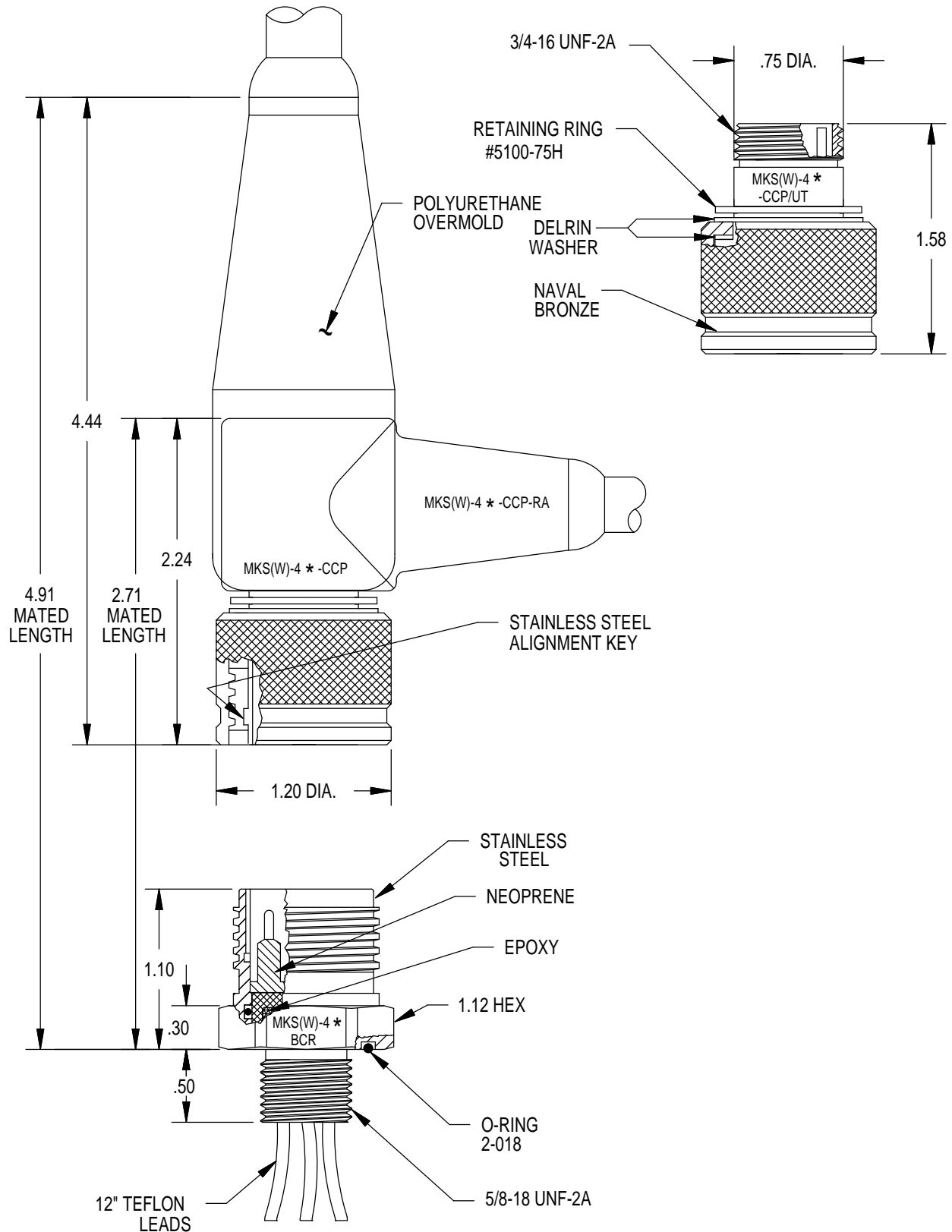

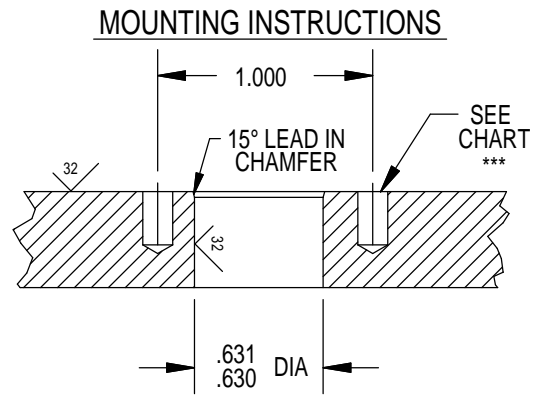
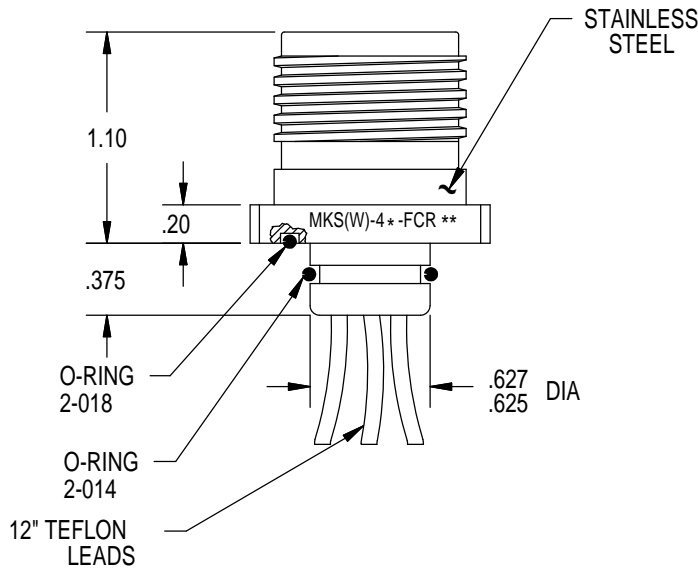
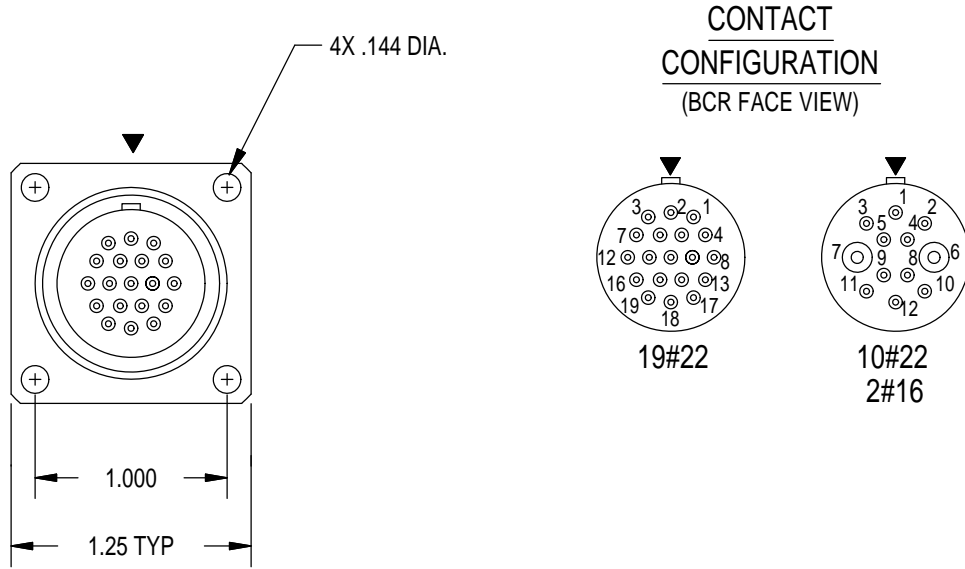

MOUNTING TORQUE FOR BCR	not to exceed 100 in lbs	MATED PRESSURE RATING (psi)	10,000
See pg. 9580 for SCP/SCR information.			
<p>NOTE: CCP is not terminated to cable unless specified.</p> <p>* Please specify number of contacts.</p> <p>** Internal assembly same as MKS(W)-4* -BCR (facing page).</p> <p>*** Blind tapped hole not to penetrate bulkhead, minimum full thread depth 2 times bolt diameter.</p>			

MKS(W)-5

METAL KEY WET PLUGGABLE RUBBER MOLDED TITAN™ SERIES

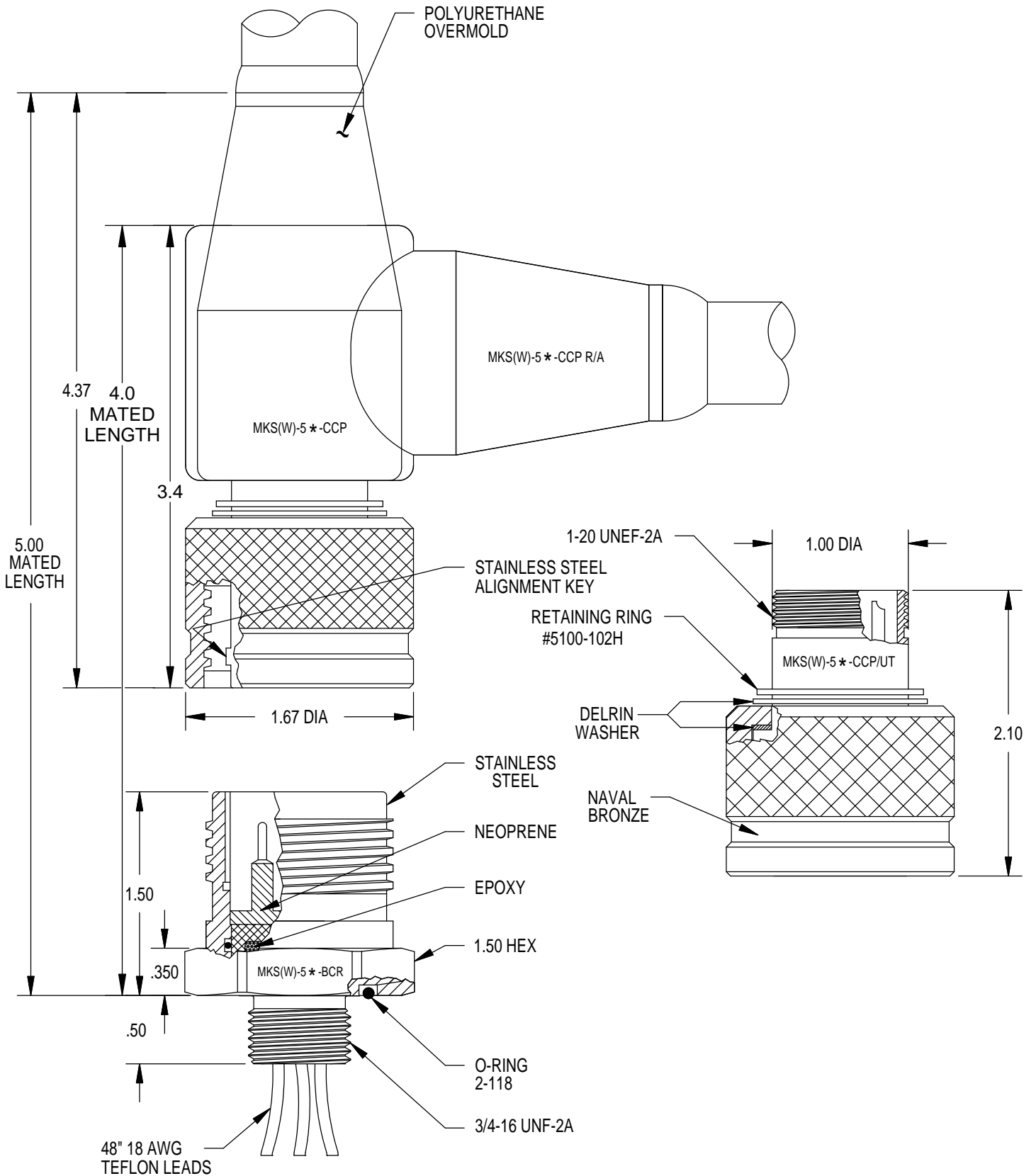

MKS(W)-5

METAL KEY WET PLUGGABLE RUBBER MOLDED TITAN™ SERIES

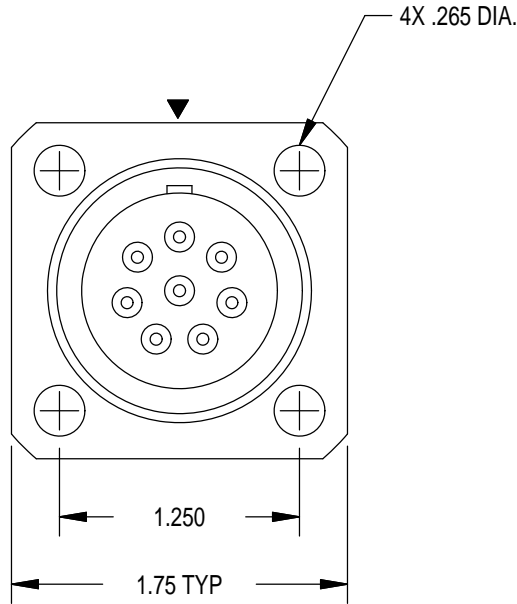

CONTACT CONFIGURATIONS (BCR FACE VIEW)

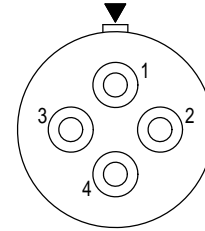

4#10

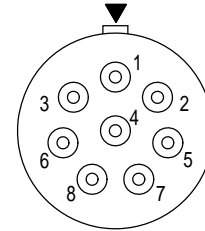

8#16

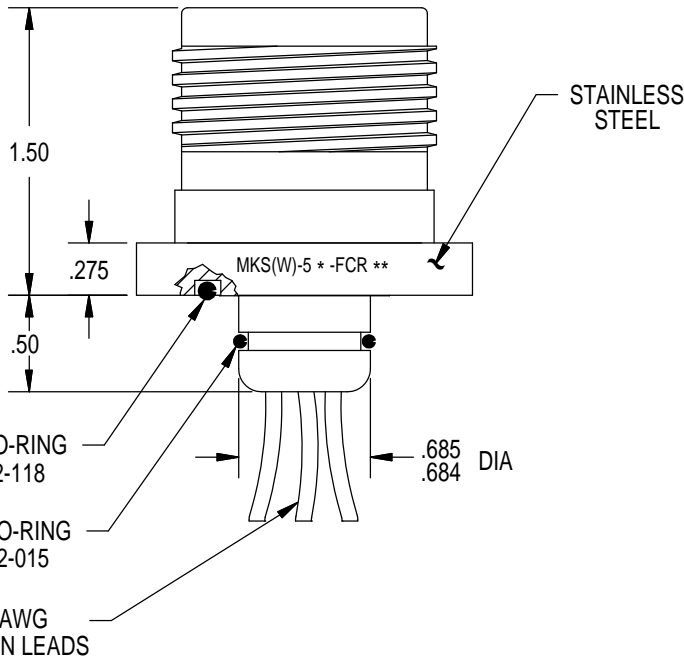

MOUNTING INSTRUCTIONS

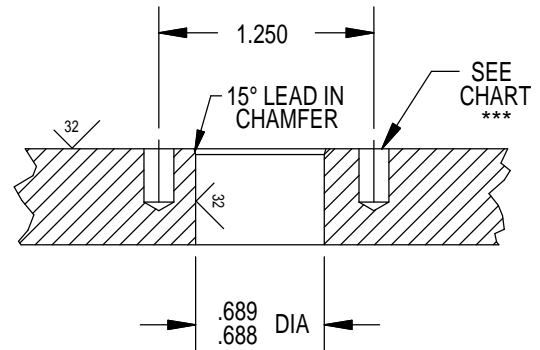

MOUNTING TORQUE FOR BCR	not to exceed 165 in lbs	MATED PRESSURE RATING (psi)	10,000
-------------------------	--------------------------	-----------------------------	--------

See pg. 9580 for SCP/SCR information.

NOTE: CCP is not terminated to cable unless specified.

* Please specify number of contacts.

** Internal assembly same as MKS(W)-5* -BCR (facing page).

*** Blind tapped hole not to penetrate bulkhead, minimum full thread depth 2 times bolt diameter.

MKS(W)-7

METAL KEY WET PLUGGABLE RUBBER MOLDED TITAN™ SERIES

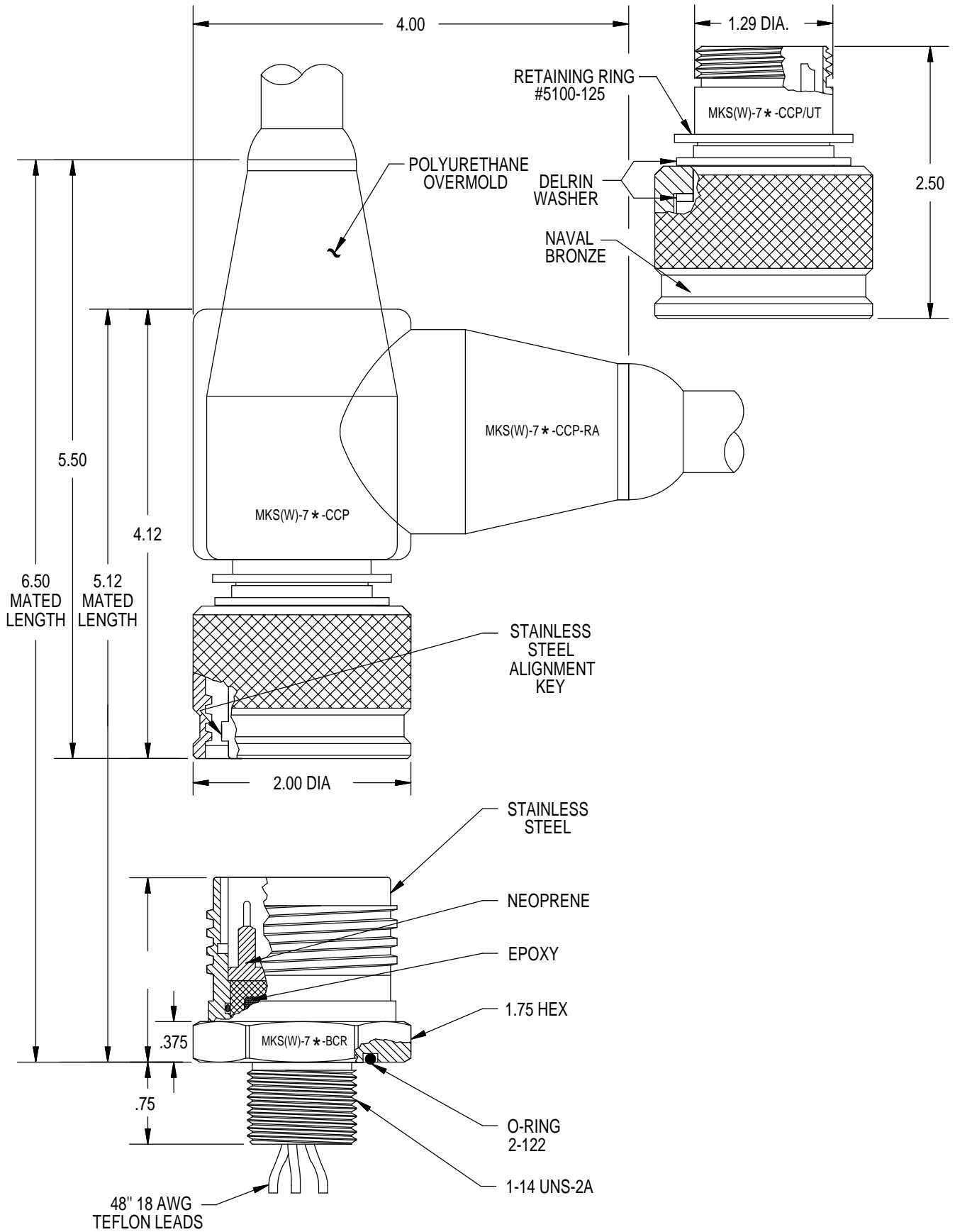

MKS(W)-7

METAL KEY WET PLUGGABLE RUBBER MOLDED TITAN™ SERIES

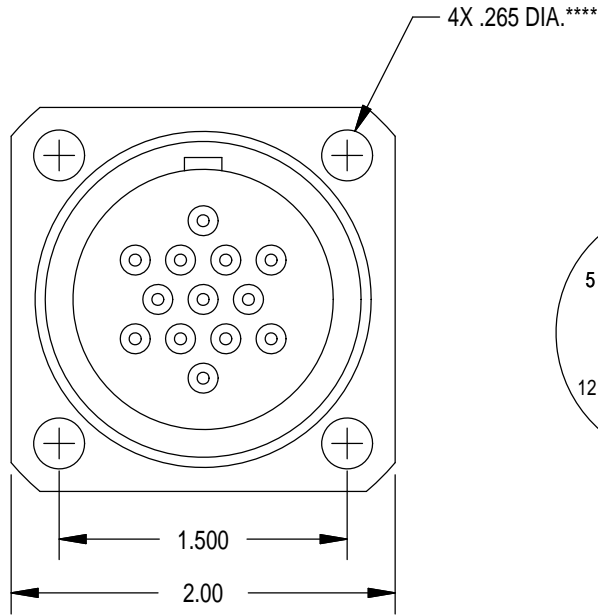

CONTACT CONFIGURATION (BCR FACE VIEW)

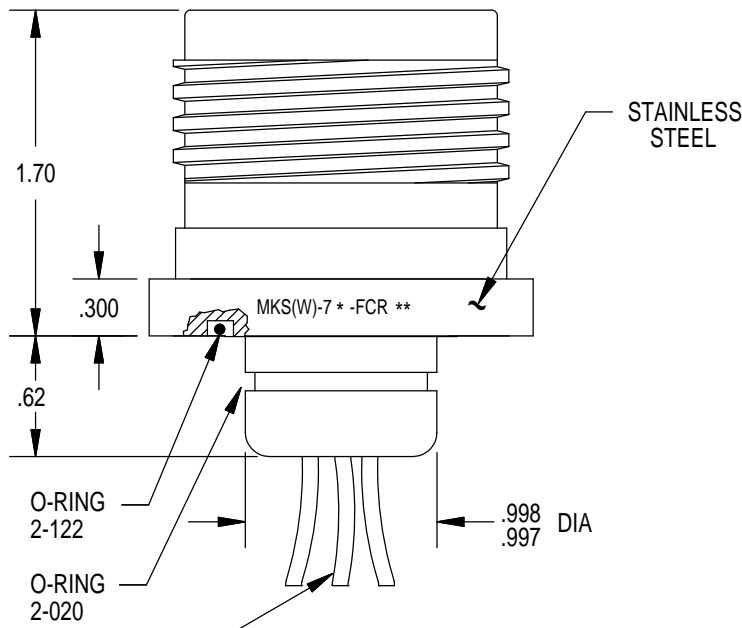
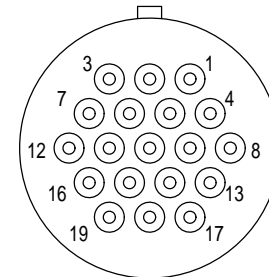
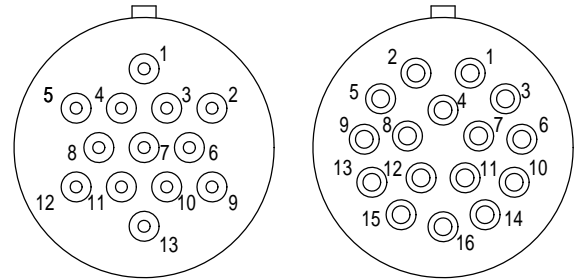

MOUNTING INSTRUCTIONS

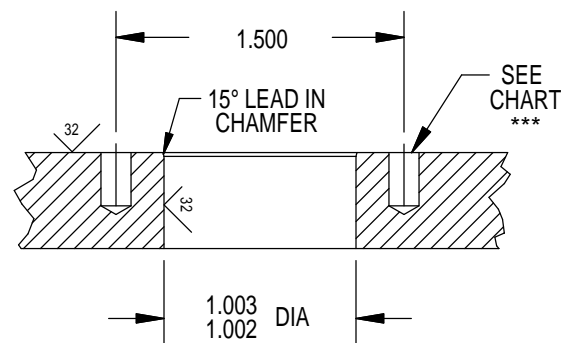

48" 18 AWG
TEFLON LEADS

MOUNTING TORQUE FOR BCR	not to exceed 225 in lbs	MATED PRESSURE RATING (psi)	10,000
See pg. 9580 for SCP/SCR information.			
<p>NOTE: CCP is not terminated to cable unless specified.</p> <p>* Please specify number of contacts.</p> <p>** Internal assembly same as MKS(W)-7* -BCR (facing page).</p> <p>*** Blind tapped hole not to penetrate bulkhead, minimum full thread depth 2 times bolt diameter.</p> <p>**** Modified M6 socket head cap bolts are available.</p>			

MKS(W)-9

METAL KEY WET PLUGGABLE RUBBER MOLDED TITAN™ SERIES

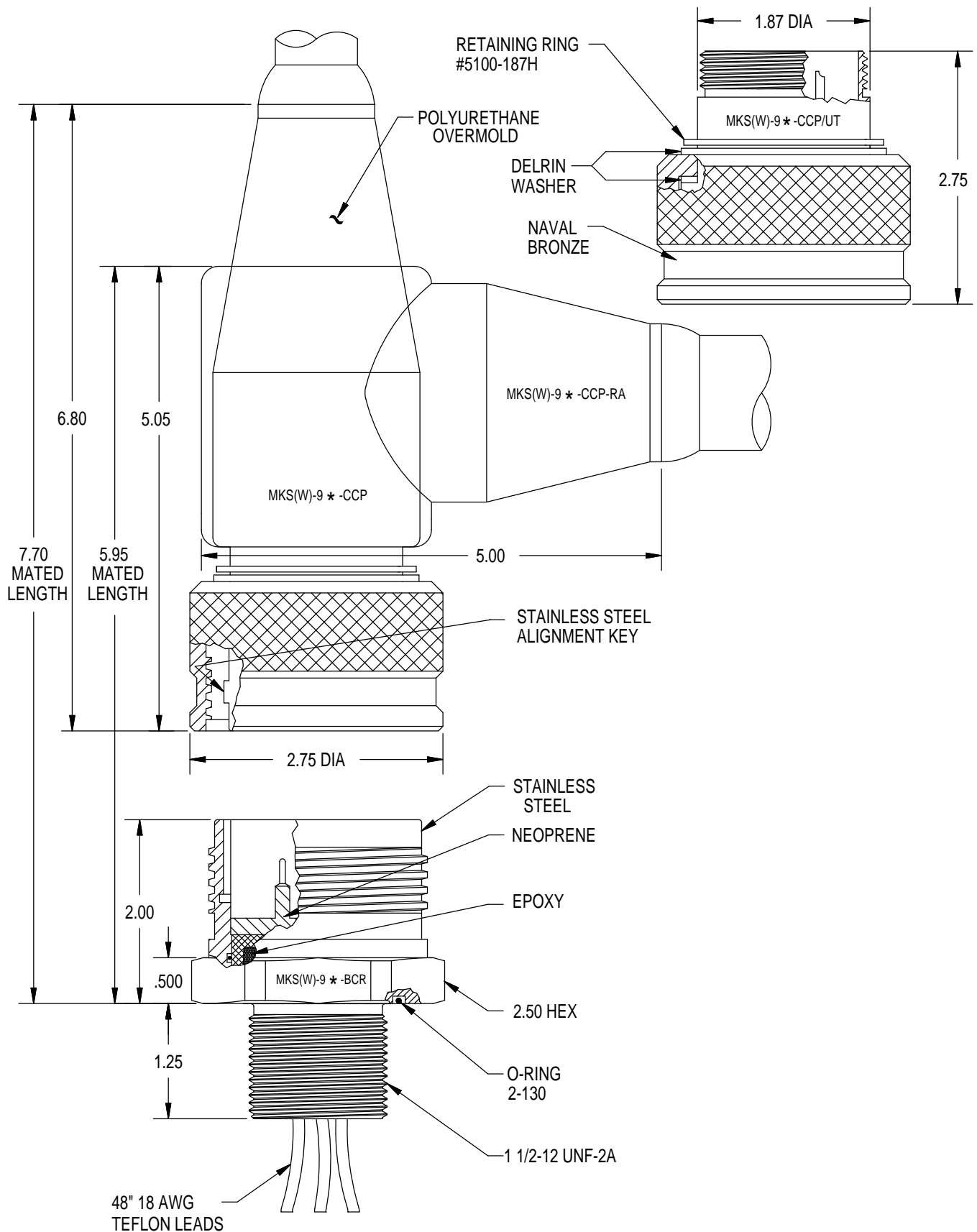

MKS(W)-9

METAL KEY WET PLUGGABLE RUBBER MOLDED TITAN™ SERIES

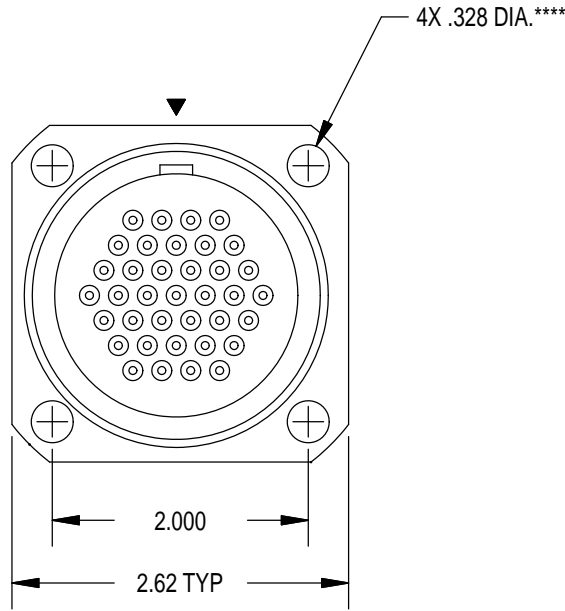

CONTACT CONFIGURATION (BCR FACE VIEW)

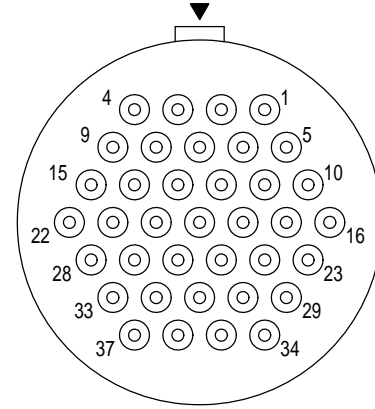

37#16

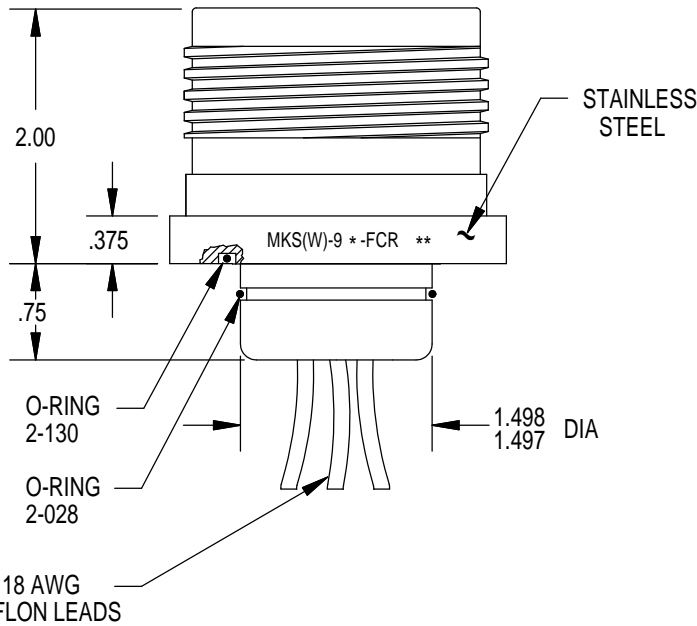

MOUNTING INSTRUCTIONS

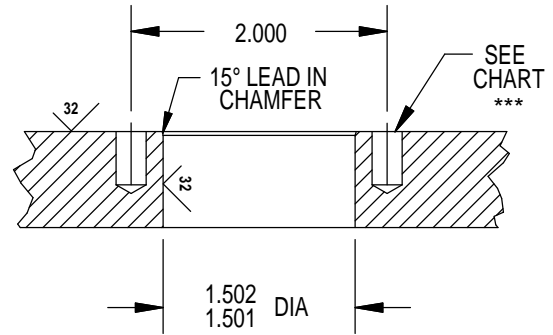

MOUNTING TORQUE FOR BCR	not to exceed 335 in lbs	MATED PRESSURE RATING (psi)	10,000
-------------------------	--------------------------	-----------------------------	--------

See pg. 9580 for SCP/SCR information.

NOTE: CCP is not terminated to cable unless specified.

* Please specify number of contacts.

** Internal assembly same as MKS(W)-9 * -BCR (facing page).

*** Blind tapped hole not to penetrate bulkhead, minimum full thread depth 2 times bolt diameter.

**** Modified M8 socket head cap bolts are available.

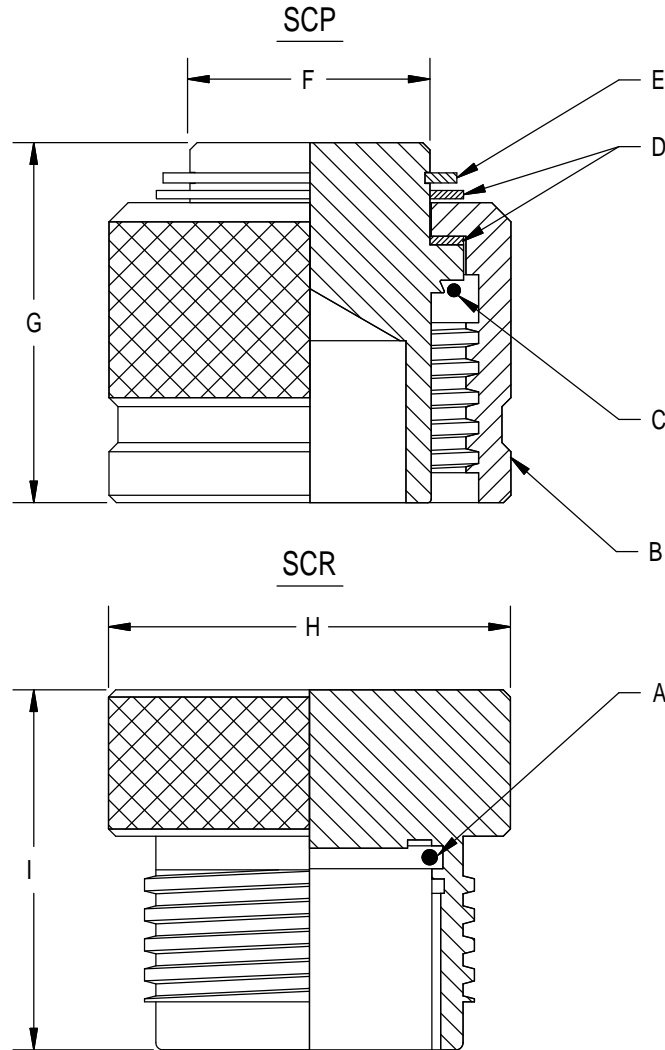

CONNECTOR SIZE	MKS-200	MKS-300	MKS-400	MKS-500	MKS-700	MKS-900
A O-RING	5-712	5-682	2-018	2-022	2-028	2-032
B ENGAGING NUT	452110	453115	462525	472527	482623	483107
C O-RING	5-057	5-682	5-003	2-023	2-028	2-033
D DELRIN WASHER(2X)	452101	453001	462530	472501	482618	483101
E RETAINING RING	5100-37	5100-43	5100-75	5100-102	5100-125	5100-187
F DIA	.37	.44	.76	1.00	1.29	1.87
G	.65	.75	1.15	1.50	1.87	2.00
H DIA	.60	.71	1.20	1.67	2.00	2.67
I	.58	.75	1.10	1.50	1.60	2.10
SCR MATED PRESSURE RATING(psi)	10,000	10,000	10,000	2,000	2,000	1,000
SCP MATED PRESSURE RATING(psi)	10,000	10,000	10,000	10,000	10,000	10,000
* Metal shell SCP/SCR are not wet pluggable						
** 10,000 psi rated wet pluggable dummies available upon request.						
*** MKS-300-SCP LP (50 psi) available upon request.						
**** MKS(W)-3L10 uses wet pluggable dummies only.						